

SOLID

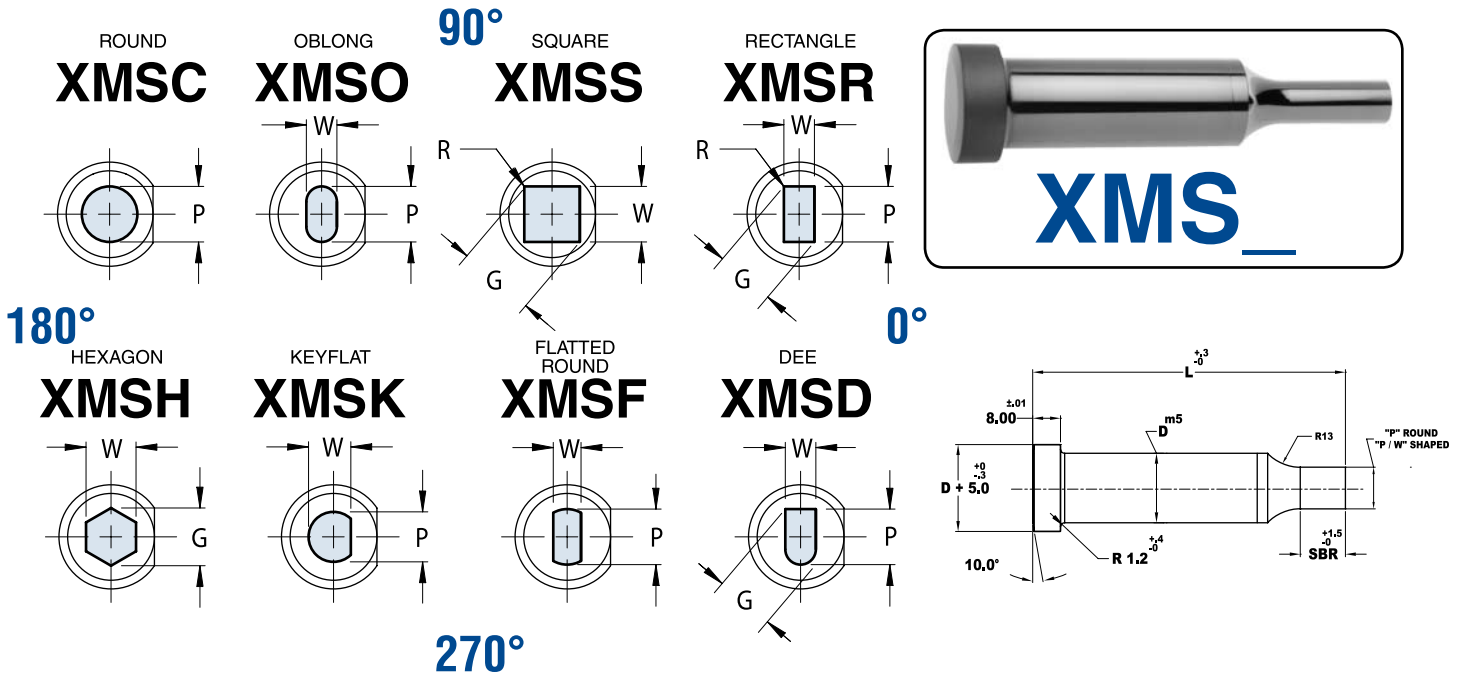

VIEWS ARE SHOWN LOOKING THROUGH THE SHANK BUT DRAWN WITH SOLID LINES FOR CLARITY.

FOR STANDARD ALTERATIONS SEE MASTER CATALOG

SHANK CATALOG TYPE	ROUND DIA D	ROUND	SHAPE		OVERALL LENGTH "L"			
		RANGE P	MIN W	MAX G/P	70	80	90	100
XMS_10	10	3.20 - 9.99	3.20	10.00	X	X	X	X
XMS_13	13	5.00 - 12.99	4.50	13.00	X	X	X	X
XMS_16	16	8.00 - 15.99	6.00	16.00	X	X	X	X
XMS_20	20	10.00 - 19.99	8.00	20.00	X	X	X	X
XMS_25	25	12.00 - 24.99	9.00	25.00	X	X	X	X
XMS_32	32	16.00 - 31.99	10.00	32.00	X	X	X	X

Material
 Steel: CPM M4 RC 60-62
 Heads RC 40-55

Standard Point Tolerance

Round P $\pm .0005$ $\pm .0000$.0005 P to D

Shape P, W $\pm .0005$.001 P to D

CATALOG TYPE	SHANK D	POINT LENGTH "SBR"	
		STD	ALTERNATE B
XMS_10	10	13	19
XMS_13	13	13	19
XMS_16	16	19	25
XMS_20	20	19	25
XMS_25	25	19	25
XMS_32	32	19	25

L=50 SBR MAX=13 L=60 SBR MAX=19
 L=56 SBR MAX=19 L=63 SBR MAX=25

STANDARD FLAT LOCATION IS AT 0° AS SHOWN.
 AVAILABLE AT 90°, 180°, 270°, FOR SAME ALTERATION PRICE.